

OPERATING INSTRUCTIONS

MANKAR HQ



**ULV- Applicator for weed control
in areas of specialised cultivation such as nurseries, orchards and
vineyards, ornamental plant and vegetable gardens, as well as
agricultural, forestry, communal and non-cultivated lands.**

**The unit has been developed for the *undiluted*
application of ROUNDUP® products (Glyphosate).**

Important:

Before application, carefully read the usage instructions for the unit and the plant protective agent!
Observe safety instructions!

For questions regarding plant protective agents, consult the manufacturer!

Observe the requirements and regional regulations for the use of herbicides and, if necessary, obtain approval from the responsible authorities (e.g. environmental conservation agency)!

Application is to be performed only by a competent user.

Remarks about usage of the unit:

Settings: This system is not suitable for the application of water.

Use herbicides for testing the spray action and calibration of the flow rate.

Usage: Position the spray hood directly above the ground –
if the spray hood is held too high, the danger of spray driftage exists.

Cleaning: Do not clean the unit with a high-pressure spray or an intense water jet spray.

Storage: Store the unit at an angle of between ca. 45° (= work position) and 0° (= horizontal) to the floor (see picture).



Keep the applicator and pesticides out of the reach of children.

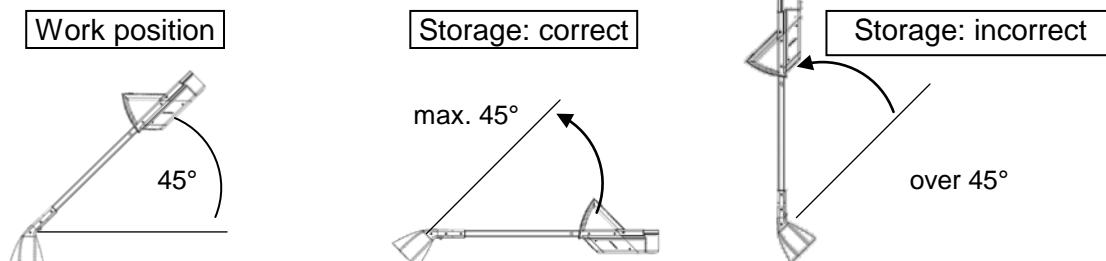

Noise emission from the unit equates to less than 70 dB(A).

Manufacturer:

Mantis ULV-Sprühgeräte GmbH

Germany 21502 Geesthacht, Vierlander Str. 11 a

Telephone +49(0)4152-8459-0, FAX +49(0)4152-8459-11

Web: www.mantis-ulv.eu Email: mantis@mantis-ulv.eu

MANKAR HQ

Noise emission from the unit equates to less than 70 dB (A).

Protective measures

Observe remarks in the usage instructions for the pesticide regarding the safety of the user; wear recommended body protection. Wear protective gloves when filling the chemical.

Do not eat, smoke or drink while working with pesticides.

Avoid chemical spillage without fail. After completion of the work, thoroughly clean hands and face.

Thoroughly clean and dry the unit immediately following its usage. Never use the mouth to blow out nozzles or other small parts!



Keep pesticides and applicators away from children.

Assembly and preparation for the first application

Assembly of this unit is described on page 3.

Before the first application of the unit, allow the battery to charge for at least 8 hours. First plug the applicator plug into the loading socket, then plug the charging device into the 230 V power outlet. After ca. 8 hours charging time, the battery has reached its full voltage capacity. When the charging process is complete, first unplug the charging device from the 230 V power outlet, then unplug the unit plug from the charger socket.

The spray width should be subsequently checked - ideally with a piece of cardboard laid out on the ground - and the flow rate adjusted. If the unit is switched on the battery monitoring LED lights green (fig. page 3/4)

Before using the MANKAR HQ the breather hole of the lid has to be opened.

If the air-vent is closed there won't be an even chemical flow.

After usage the breather hole has to be closed to prevent leaking.

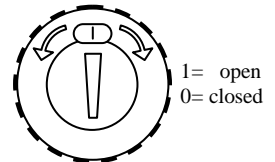

Draft of the bottle lid

General remarks about the function and regarding the application of the unit

Pesticides: This applicator was originally designed for the undiluted application of Roundup products (Glyphosate). Practical experience has shown, however, that other herbicides can also be deployed in conjunction with this technology. Considering the many products on the market with their differing formulations, it is not possible to provide a complete list with application rate recommendations. The specifications depicted below for adjusting the applicator relate to the usage of Roundup UltraMax (Glyphosate 450 gr/ltr). In general, all products with a comparable viscosity are suitable. If you intend to use a product other than Roundup UltraMax, its application should be initially tested on a trial basis over a small area. In any case, the usage instructions for the chosen herbicide should be observed along with the local requirements.

Applicator function: The rotating atomiser is driven by means of a rechargeable battery. Metering takes place by means of a metering valve. Droplets are formed by the centrifugal force of the rotating atomiser. The droplets are discharged downwards by the rotating atomiser through a step-free, adjustable segment. The residual chemical in the tank, not able to be applied, is approximately 10 ml. This residual fluid can be refilled back into the original herbicide container.

Checking applicator function: Chemicals can flow at differing rates, more quickly or slowly, due to temperature variations. For this reason, the flow rate depicted in the metering table must be checked and corrected as necessary. This technology is not suitable for the application of water. Always use herbicides for testing the spray process and for calibrating the flow rate. Check the rotating atomiser for cleanliness and free turning movement on a daily basis. Check the application volume from time to time throughout the season.

Deployment of the applicator: Position the spray hood directly above the ground - if the spray hood is held too high, the danger of spray driftage exists. During operation, chemical fluid will collect in the atomiser reservoir and can continue to drip for few seconds after pressing the switch- valve unit. Make sure that the valve of the bottle lid is open before use. After usage close the valve again to provide leakage.

Attention!

If there is any leakage the stop working and repair the unit.

Before lifting or tilting the spray hood, it is essential that the stop valve is closed and the atomiser motor is switched off.

Cleaning: It is common practice that spraying systems need a minimum of service and maintenance same applies for the MANKAR HQ. Rinse the unit with warm clear water. To accelerate the cleaning procedure a cleaning agent like "tankcleaner" can be used. Regular cleaning reduces sediments and prevents obstructions of the valve and blocking of the atomizer.

Scope of delivery and assembly

- Contents: - MANKAR HQ
 - Reservoir 0,5L HQ
 - Charger 6V
 - Shoulder strap
 - Stretch covers for spray hood
 - Operating instructions
 - Cap



MAKE SURE THAT YOU CHARGE THE MANKAR HQ

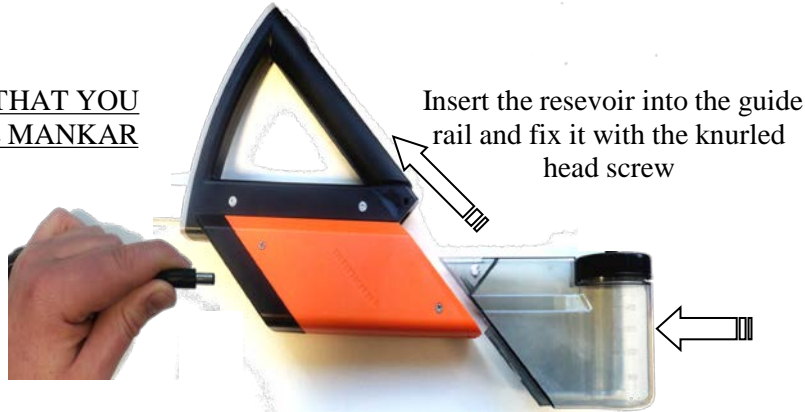

Dosing

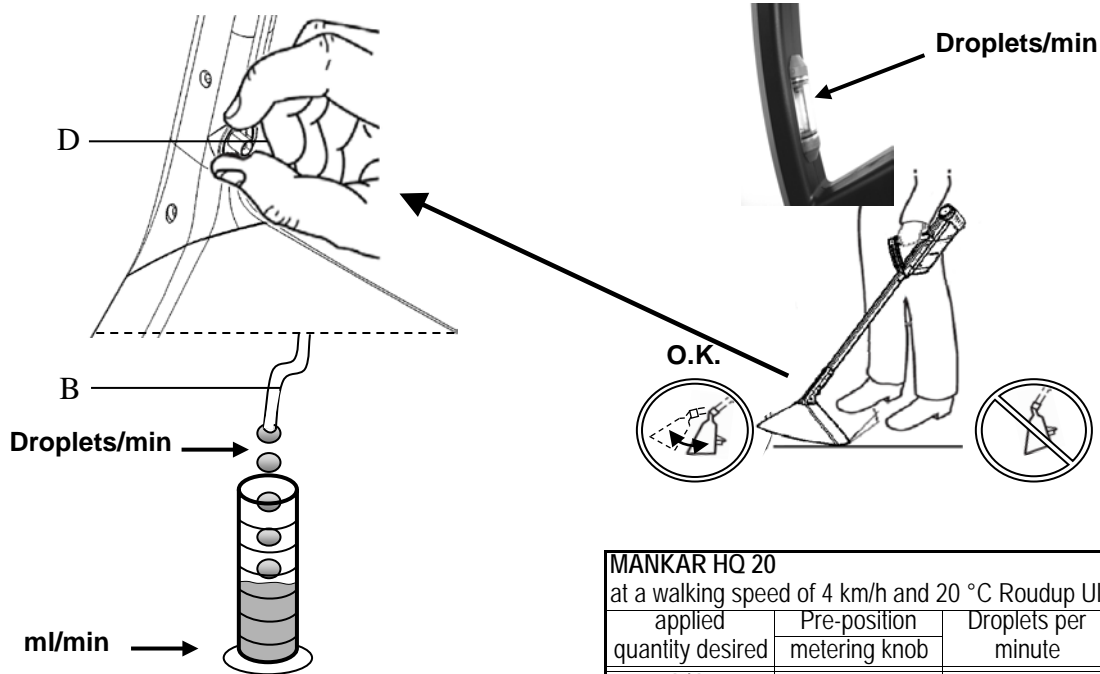

MANKAR HQ 20
 at a walking speed of 4 km/h and 20 °C Roudup UltraMax

applied quantity desired	Pre-position metering knob	Droplets per minute	ml per minute
1l / ha	A	33	1,3
2l / ha	B	67	2,7
3l / ha	B-C	100	4,0
4l / ha	C	133	5,3

MANKAR HQ 30
 at a walking speed of 4 km/h and 20 °C Roudup UltraMax

applied quantity desired	Pre-position metering knob	Droplets per minute	ml per minute
1l / ha	A-B	50	2,0
2l / ha	B-C	100	4,0
3l / ha	C	150	6,0
4l / ha	C-D	200	8,0

MANKAR HQ 45
 at a walking speed of 4 km/h and 20 °C Roudup UltraMax

applied quantity desired	Pre-position metering knob	Droplets per minute	ml per minute
1l / ha	B	75	3,0
2l / ha	C	150	6,0
3l / ha	D	225	9,0
4l / ha	E/F	300	12,0

Setting and verification

Flow rate

- Place an underlay (e.g. cardboard or paper) on the ground.
- Fill the chemical tank with herbicide (undiluted).
- Set down the applicator as pictured below.
- Remove the hose from the atomizer. (B)
- Place the measuring cylinder beneath the flow rate controller (see drawing on page 3).
- First set metering valve to maximum.  (D)
- Actuate switch/valve unit (C) and select continuous operation by pushing the button switch forward.
- When the herbicide reaches the metering valve (identifiable in the flow rate controller), the desired setting (see table) is adjusted on the valve. (D)
- Collect the herbicide for 60 sec. in the measuring cylinder.
- If desired quantity is not reached, readjust metering valve and calibrate again.
- Afterwards reattach the hose.

Example for the MANKAR HQ: The setting A is an approximation for Roundup UltraMax; 3 ml/min. Deviation from the desired volume can be regulated at the metering valve by setting a greater or lesser flow rate.

Spray width

- Hold the applicator in its working position above the overlay (e.g. cardboard or paper). Actuate the button switch and initially direct the spray hood at the underlay, appraising the spray width at various heights above the section being sprayed. The spray width must be set in such a manner that the droplets are discharged over the entire spray hood width. The optimal spray width is set by the manufacturer under standard operating conditions.
- It is possible to compensate for deviations by loosening the screw (F) and sliding the width adjustment on the atomiser (see drawing) to adjust either side so that the spray jet just misses the edge of the hood.

Working width

- The whole spray hood of the MANKAR HQ can be turned continuously to get a working width from 45 to 15 cm.

When the desired volume is obtained, the spray width verified and the working width adjusted, the application process can begin.



E. Correct rotation direction for disc

G: Setting of spray hood adjustment

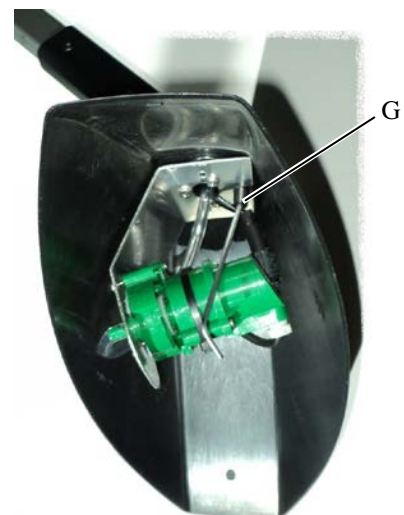
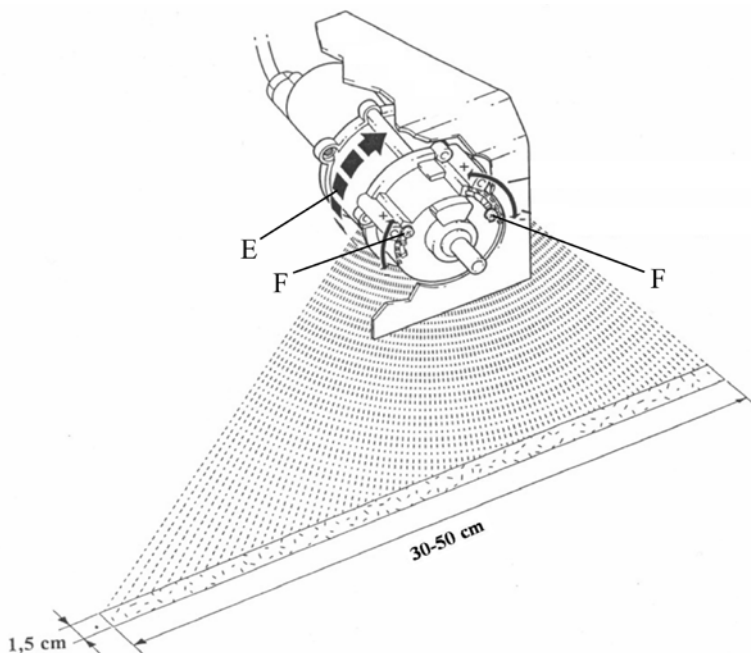

Cleaning

Do not clean the applicator with a high-pressure spray or with an intense water jet spray.

Cleaning during the season: During short breaks in the work day (a few hours), the herbicide can remain in the system as long as the metering valve is closed. After completion of work task: before cleaning, return the chemical into its original container. Set the metering valve to maximum (water cock symbol). Fill the chemical tank half way with water, actuate the button switch and allow the atomiser to run for 3 minutes over a collector tank or spread the cleaning fluid over the previously worked surface. Remove the remaining water from the tank.



Cleaning after the season: Rinse the unit with warm water or cleaning agent like "tankcleaner" as described above. The spray hood and the atomiser housing can be cleaned with a moist cloth, except the atomiser disc in order to avoid damage. For heavy contamination, the atomiser housing should be unscrewed to remove contaminants and plant parts. Connect the unit to the battery charger (see page 3).

Charging the applicator and care of the accumulator

The applicator is fitted with an automatic charging device. Trickle charging is possible.

In order to charge a completely empty battery back up to full capacity, ca. 16 hours charging time is required. When a battery is empty, it should be immediately recharged. Never leave a battery discharged for long periods.

Battery charging	Minimum charging time	Time interval
Fully discharged	8 hrs.	immediately
Short-term usage	3 hrs.	immediately
Storage without usage	(2 hrs. 1 x per month)	or permanent charge

The applicator can be used for ca. 8 hours with a fully charged battery.

Battery and motor monitoring

If the battery is fully charged the LED lights green. If the battery was charged for 8 hours and the monitoring LED still lights red, the atomiser disc might be seized. Reason for that can be insufficient cleaning. (see fault remedy below)

Another reason might be a defective battery. In this case the battery has to be replaced.



Fault remedy

Fault	Cause	Remedy
Atomiser disc not turning	Atomiser contaminated Battery empty Fuse blown	Thoroughly clean atomiser, remove plant parts if needed Charge battery Replace fuse on powerpack (Replacement fuses are located in the powerpack housing)
	No electrical contact Battery defective Atomiser motor defective	Check cable or connector contact Install new battery Install new motor module
Atomiser spray one-sided	Rotation disc turning in the wrong direction	Connect cable correctly! Selectively plug the brown cable onto the contact pin on the switch/valve unit Connect the blue cable via the round pin plug. Check to ensure the battery connection to the powerpack is correctly poled, brown cable to Plus (+).
Atomiser spray too wide	Width adjustment improperly set	Loosen the screw (F, see page 4) and correct the width setting to the left or to the right, respectively
Atomiser drips	Metering valve incorrectly set Atomiser disc defective / contaminated Atomiser spray discharge contaminated	Check setting, see table Replace / clean disc Clean
Atomiser foams	Residual water in system	Completely empty container, hose, segmental atomiser.
Chemical not flowing evenly	Metering valve clogged	Set scale to maximum  flush the unit with warm water or use cleaning syringe (accessory art.-no. 100348).
	Breather hole of the lid is clogged	Clean the lid with warm water

Components und spare parts for MANKAR HQ

Pos.	Part No.	Description
1	102905	Cover for frame, left, HQ
	102906	Cover for frame, right, HQ
2	102908	Grip front plate, MANKAR HQ
3	103341	Grip-frame, left, MANKAR HQ
	103342	Grip-frame, right, MANKAR HQ
4	103343	Spray hood beam with electronics, socket and fuse holder complete
5	102901	Shaft-spray hood adjustment, left, HQ
	102902	Shaft-spray hood adjustment, right, HQ
6	102907	Spray hood 45 cm, MANKAR HQ
7	103441	Installation kit, spray hood 20 cm, MANKAR HQ
8	100979	Spray hood 20 cm, MANKAR HQ
9	103442	Installation kit, spray hood 30 cm, MANKAR HQ
10	101662	Spray hood 30 cm, MANKAR HQ
	102965	Screw set

102445 Automatic charger 100-240AC, 6VDC/450mA

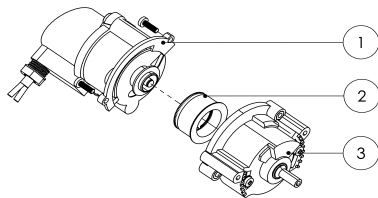
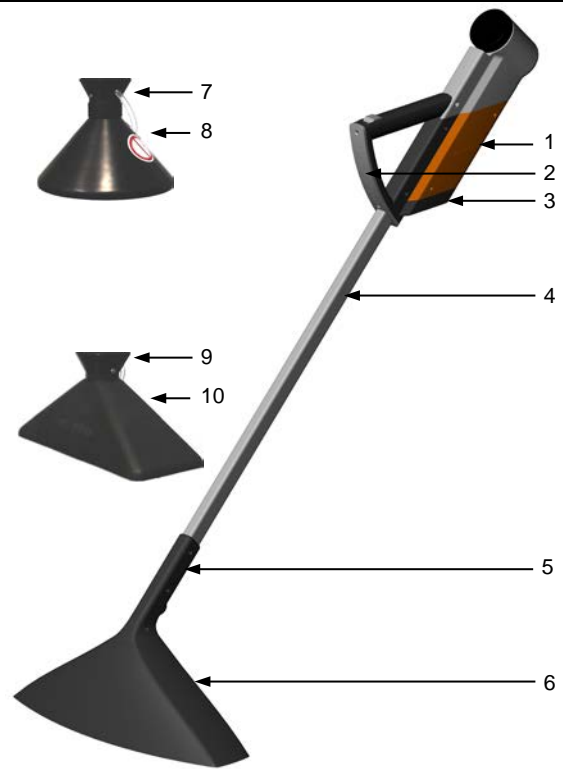

Pos.	Part No.	Description
	103150	Atomiser, hand-held unit MANKAR HQ
1	103153	Motor-module for atomiser MANKAR HQ
2	100478	Atomiser disc for herbicide atomiser
3	101996	Segment-module for atomiser

Pos.	Part No.	Description
	102915	Dosing valve for MANKAR HQ

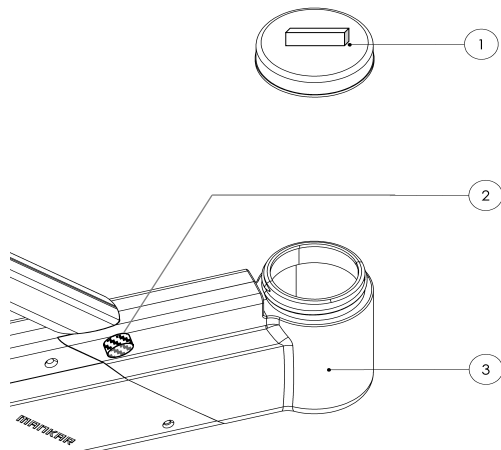
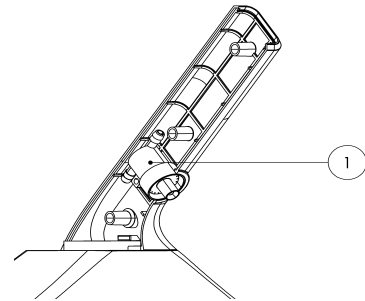

1	103320	Bottle lid for 0,5 litre reservoir with breather
2	102958	Knurled screw M 4 x 20 mm VA
3	103323	Reservoir 0,5L , MANKAR HQ

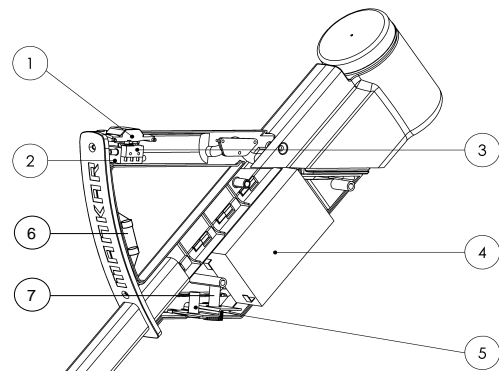

1	102946	Slideknop, MANKAR HQ
2	102914	Valve unit, MANKAR HQ
3	102890	Switch, MANKAR HQ
4	100248	Battery 6V-3,8Ah
5	100693	Socket, d=2,1 mm
6	103319	Flow rate controller, complete for Mankar HQ
7	100365	Fuse holder complete

Storage in the case



1. Disconnect the tank of the unit *
2. Empty the tank. The undiluted herbicide can be decanted into the original tank.
3. Fill the tank half with water or cleaning agent for example "Tankcleaner" and mount it.
4. Set the Dosing valve to the max (water tap symbol)
5. Switch the unit on (switch on hand grip) let it run for app. 3 minutes
6. Disconnect the tank empty it and put it into the case *
7. Charge the MANKAR HQ with the attached charger
8. The unit can be cleaned with a moist cloth
9. Put the MANKAR HQ and charger for protection back into the case. *

If you follow the instructions for cleaning and maintenance, the MANKAR HQ will give pleasure to you al tong time

* Point 1, 6 and 9 just refer to the storage in the case.

GUARANTEE

- I. If the purchase is a commercial transaction for both sides, the Customer must examine the goods immediately on receipt, as far as this is possible during the regular course of business and if there is a defect, inform the Vendor immediately.
- II. If the Customer does not make a complaint, the goods are considered approved, unless there is a defect, which was not visible during the examination. Furthermore §§ 377 ff. HGB applies.
- III. The Vendor may choose to eliminate the defects or deliver an item free of defects, (rectification of defects). If the rectification of defects fails, the Customer has the right to choose to either demand a reduction in price or to withdraw from the contract.
- IV. Further claims from the Customer, in particular due to consequential damage caused by a defect are in principle disqualified. This does not apply in cases of intent, gross negligence or breaches of contract by the Vendor as well as in cases of injury to life, body or health. The right of the Customer to withdraw from the contract remains unaffected.
- V. Warranty claims lapse after 24 months, respectively after 12 months in case of commercial use of the goods. The limitation period begins at delivery. The guarantee expires, if the delivered goods change or are handled incorrectly.
- VI. The Vendor is not responsible for material defects on deliveries, which he sources from third parties and forwards unchanged to the Customer. Responsibility in the case of intent or negligence remains unaffected. The preceding regulations do not imply a change to the burden of proof to the disadvantage of the Customer.
- VII. Claims for defects do not only exist in cases of negligible deviations from the agreed properties and conditions or only in negligible impairment of usefulness.
- VIII. Necessary expenses for the purpose of the rectifying defects are to be paid by the Customer, if they increase due to delivery to a different place than the place of business of the Customer, unless the transport corresponds to its intended use.

EG-Declaration of conformity Council Directive 2006/42/EG

Mantis ULV-Sprühgeräte GmbH, Vierlander Straße 11 a, 21502 Geesthacht declares under our sole responsibility that the following products are in conformity with the provisions of the following Council Directive: 2006/42/EG

Typ MANKAR-P, MANKAR-110-P, MANKAR-110-GP, MANKAR-L,
MANKAR-110 SELECT EL
Typ MANTRA, MINI-MANTRA / PLUS, MICRO-MANTRA, MICRO-VASO,
MANKAR HQ
Typ FLEXOMANT-1W, FLEXOMANT-2W, FLEXOMANT-3W, FLEXOMANT-4W,
FLEXOMANT-PLUS, VARIMANT-1, VARIMANT-2, VARIMANT-4 PLUS,
VARIMANT-WINNER-TOP, VARIMANT-WINNER-UNO
Typ MAFEX
Typ ROFA

André Verder
Managing Director

Geesthacht January 2011

(Place and date of signature)

(Name, title and signature)